

Lab 8: Full System Integration (Session II)

Date		Grade
Names		
		Lab session / lab room

You have to submit this report via Moodle.

Use a zip file or tarball that contains the report and any other required material. Only one member from each group should submit the report. All members of the group will get the same grade.

The name of the submitted file should be *Lab8_LastName1_LastName2.zip* (or *.tar*), where *LastName1* and *LastName2* are the last names of the members of the group.

Note 1: Please include all the required material. No links/shortcuts are accepted.

Note 2: The deadline for the report is a hard deadline and it will not be extended.

Exercise 1

Below is a part of the MIPS block diagram. Draw the necessary modifications for the memory-mapped I/O on this block diagram. (We are only interested in the SW and LW instructions; the rest of the block diagram has been purposefully left out. *Hint: If your circuit works, you already implemented this in the MIPS.v module.*)

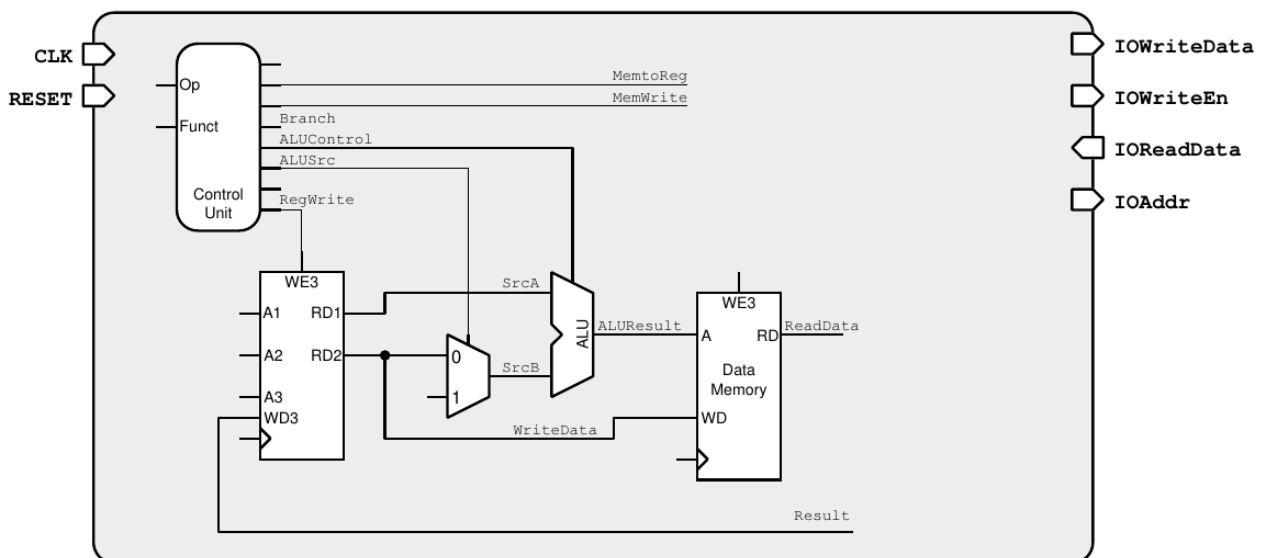

Exercise 2

Using Figure 1 as a reference, what additional hardware/architectural changes are needed in the top module (*top.v* file) to implement Challenge 2 described in the Manual of Lab 8, Session 2? You can either draw the additional circuitry required or write in your own words here.

Feedback

If you have any comments about the exercises (e.g., related to mistakes in the text, the difficulty level, or anything else that will help us improve them), please submit them through Moodle, using the corresponding “Lab 8.2: Feedback” form:

<https://moodle-app2.let.ethz.ch/course/view.php?id=16852#section-2>